

**FOX** REDEFINE  
**YOUR LIMITS**

FLOAT 3 EVOL R  
**CHRIS BURANDT SIGNATURE SERIES**  
OWNERS MANUAL



## CONTENTS

CONGRATULATIONS.....	3
CONSUMER SAFETY.....	3
UNDERSTANDING THE FLOAT 3 EVOL R.....	4
FOX PUMP.....	5
OPTIONS.....	5
ADJUSTABLE PROGRESSIVE AIR SPRING.....	6
REFERENCE AIR PRESSURES.....	7
TEMPERATURE DEPENDENCY.....	7
MEASURE STOCK SETTINGS.....	8
INSTALLING YOUR SHOCKS.....	10
FLOAT 3 EVOL R INSTALLATION.....	11
FLOAT 3 EVOL R SETUP.....	12
TUNING THE FLOAT 3 EVOL R.....	14
REBOUND ADJUST.....	14
TUNING NOTES.....	15
MAINTENANCE.....	16
SERVICE.....	16
WARRANTY.....	16

NOTICE: THE SNOWMOBILE PICTURED IN THIS MANUAL MAY NOT RESEMBLE YOUR ACTUAL SNOWMOBILE. THE PROCEDURES OUTLINED IN THIS MANUAL WILL INSTRUCT YOU TO MOUNT, SET-UP AND ADJUST THE FOX FLOAT 3 EVOL R SHOCK ABSORBER ON YOUR PARTICULAR SNOWMOBILE MODEL.

Reference print standards 604-00-300 rev A

## CONGRATULATIONS

Thank you for choosing FOX FLOAT 3 EVOL R CHRIS BURANDT SIGNATURE SERIES shock absorbers for your snowmobile. In doing so, we believe that you have chosen the finest suspension products in the world. FOX shocks have been designed, tested and manufactured in the USA for more than 40 years.

As a consumer and supporter of FOX products, you need to be aware of the importance of setting up your shocks correctly to ensure maximum performance. This manual provides step-by-step instructions on how to set-up and maintain your shocks. It is a good idea to keep your proof of purchase with this manual and refer to it for service and warranty issues.

This manual does not contain step-by-step shock rebuild instructions. Rebuilding should be carried out by an authorized FOX service technician.

## CONSUMER SAFETY

**WARNING:** Riding a Snowmobile can be dangerous and can result in DEATH OR SERIOUS INJURY.

Take responsibility for yourself and others seriously, and read the following safety tips:

- Keep your vehicle and its suspension systems in optimal working condition.
- Always wear protective clothing, eye protection and a helmet
- Know your limits and ride within them!

The FOX FLOAT 3 EVOL R shock contains a high-pressure nitrogen charge. The shock should only be opened by a FOX technician.

**WARNING:** Opening a nitrogen pressurized shock can be dangerous and can result in SERIOUS INJURY OR DEATH. NEVER attempt to disassemble the damper of your FLOAT 3 EVOL R shock. Do not puncture or incinerate the shock absorber damper portion. Always wear eye protection when installing or adjusting your shock absorber.

## UNDERSTANDING THE FLOAT 3 EVOL R

FOX FLOAT (FOX Load Optimizing Air Technology) 3 EVOL R air shocks are high- performance shock absorbers that use air as springs, instead of heavy steel coil springs or expensive titanium coil springs. Underneath that air sleeve is a high- performance, velocity-sensitive, shimmed damping system. FLOAT 3 EVOL R air shock dampers contain high pressure nitrogen gas and FOX high viscosity index shock oil separated by an Internal Floating Piston system. This helps to ensure consistent, fade-free damping in most riding conditions.

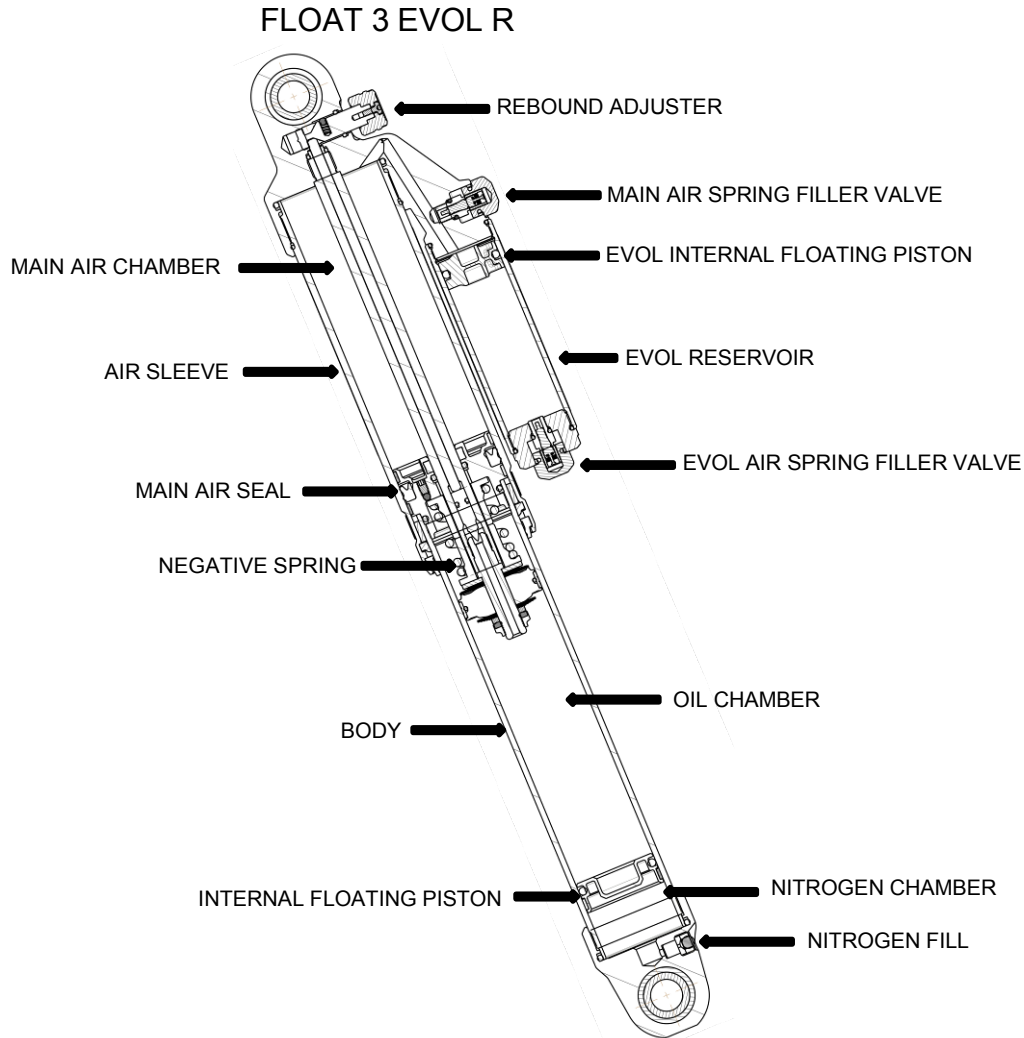

FLOAT 3 EVOL R shocks are built using 6061-T6 aluminum for lightweight and strength. The chromed damper shaft is super-finished for low friction and long seal life. All of the seals and wipers are engineered specifically for FLOAT 3 EVOL R. The damper shaft and seals are contained within the air sleeve, protecting them from dirt, water and ice.

## FOX PUMP

Your FLOAT 3 EVOL R shock absorbers are shipped with a FOX dual scale air pump, shown below.



0-300psi Dual Scale Pump P/N 027-00-008

## AVAILABLE OPTIONS



0-300psi Digital Pump P/N 027-00-010



Body Guard Kit, black shown, optional colors available

## ADJUSTABLE PROGRESSIVE DUAL-STAGE AIR SPRING

Air springs are not just lightweight they are also progressive. What does that mean? As the graph below shows, during the second half of shock travel, the spring force builds rapidly. This virtually eliminates any harsh bottoming of the suspension and provides a “bottomless” feel.

With just one pump you can make quick, easy changes to your setup to fine tune your shock’s spring curve. Using air, there is an infinite number of spring rates available.

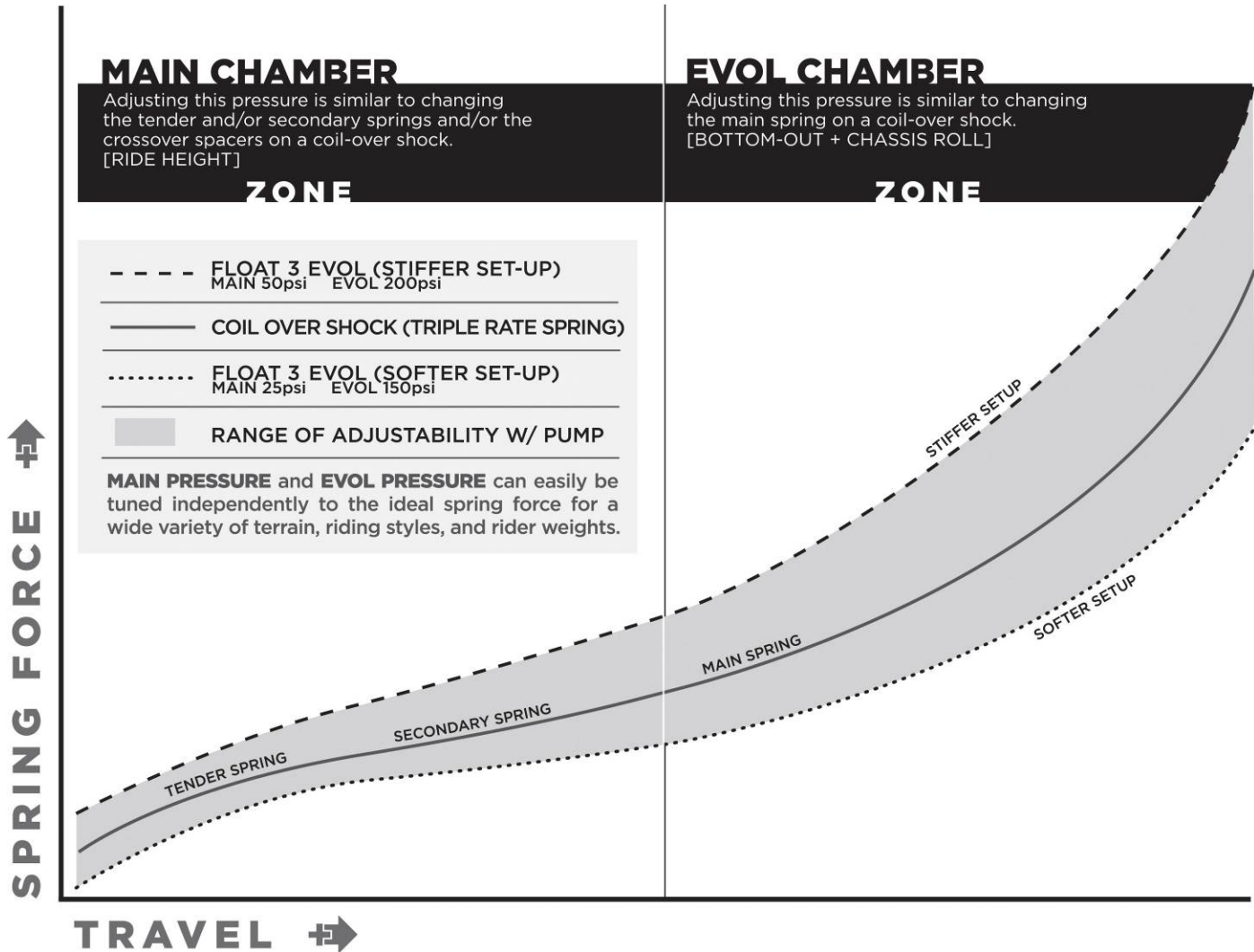

As you can see, by changing the pressures in the **MAIN** air chamber and the **EVOL** air chamber, you can get much softer or much firmer than a coil-over shock without ever having to change out a spring.

Your FLOAT 3 EVOL R shocks come in the box ready-to-ride, but we encourage you to follow the procedures outlined in this manual to optimize their performance.

The air pressure in the EVOL air chamber is adjusted to control the vehicle corner roll and bottom-out characteristics in the last 1/3 of shock travel; the pressure in the MAIN air chamber is adjusted to change ride height and the suspension stiffness of the snowmobile.

Reference Air Pressures

	EVOL Air Chamber	Main Air Chamber
Mountain/Backcountry	100-150	45-65
Performance/Trail	160-180	55-95
Sno-Cross/X-Country	200-250	100-120

The effects of changing the EVOL air chamber pressure and MAIN air chamber pressure are shown in the graphs below:

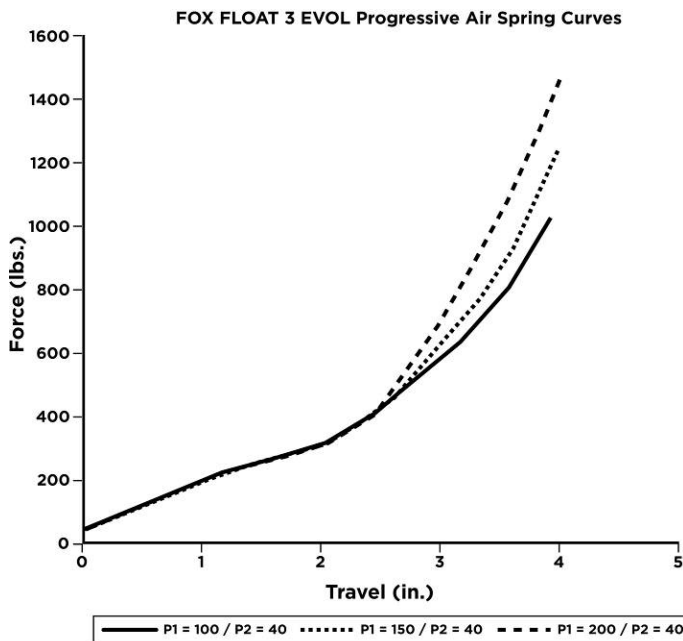

Changing EVOL Air Chamber pressure adjusts the bottom-out resistance of the shock.

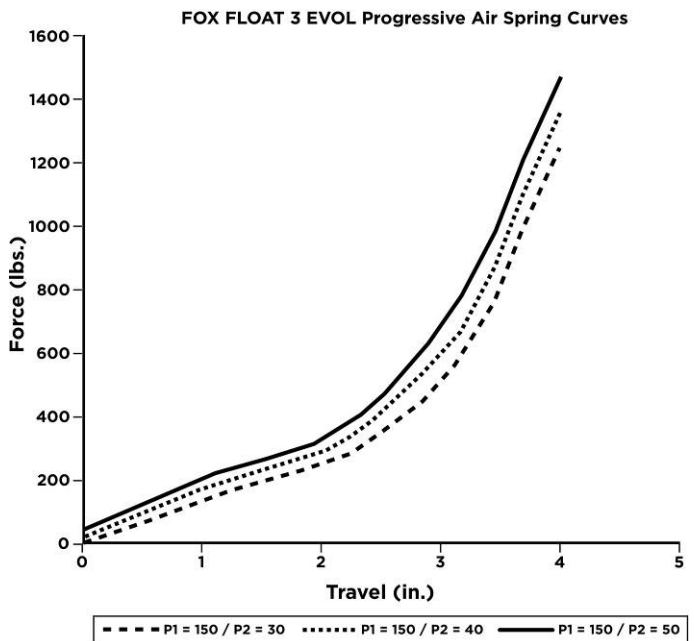

Changing MAIN Air Chamber pressure steadily adjusts the spring curve.

## TEMPERATURE DEPENDENCY

The air pressures in the FLOAT 3 EVOL R air shocks are slightly temperature dependent with roughly a 10psi air pressure change over a 100-degree temperature change. Because of this, it is best to set the pressures in temperature conditions close to the ambient temperature anticipated during riding. When temperatures change by more than 30 degrees Fahrenheit—or 17 degrees Celsius—it is recommended that the pressure settings be reset.

For example, if the temperature outside is 40°F (4°C) and the pressures are set while the snowmobile is in a garage in which the ambient temperature is 70°F (21°C), the shocks will be under-pressurized when taken outside due to the cold air temperature. Therefore, it is imperative that the pressures are re-adjusted when the snowmobile/shocks are taken from extreme warm to cold temperatures and vice-versa. Once the pressures are set for a given temperature, they will remain stable throughout the ride.

## MEASURE STOCK SETTINGS



### Step 1 BEFORE REMOVING STOCK SHOCK ABSORBERS

Start with the vehicle on a flat surface. Push down on the front bumper 3 times to settle the front end. Measure the ground clearance of the stock vehicle with the rider on board, from the low point of the chassis. This will be measurement A = 9.500"  
This measurement is known as ride height.

Ride height is measured with the intended rider and gear on board the vehicle, then taking the measurement.





Step 2 Raise the front end up until the shocks fully extend or the skis are just about to come off the floor. Re-measure from the previous point on the chassis to the ground. This will be measurement B (Example 11.125") Full Extension

Step 3 **B - A = Sag Example 11.125" - 9.500" = 1.625" of Sag**  
Use this measurement to set up your FOX FLOAT 3 EVOL R

Full Extension – Ride Height = Sag

Sag requirement is dependent on your vehicle, rider weight and usage. Sag requirements may vary. Heavier vehicles and riders may require more sag for optimal performance.

## INSTALLING YOUR SHOCKS

If you do not have the proper equipment, tools, floor jack or jack stand, torque wrench, ratchet socket set with wrench set and abilities to correctly install your shock, have the shock absorbers installed by a professional technician. Your shock absorbers come supplied with the correct reducers pre-installed to mount them correctly to your vehicle.

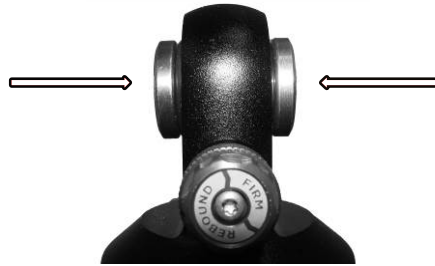

**WARNING: CONTACT FOX IF THESE REDUCERS DO NOT FIT CORRECTLY. CORRECT SHOCK MOUNTING IS CRITICAL FOR CORRECT OPERATION AND FOR YOUR SAFETY.**



DO NOT REMOVE NITROGEN FILL VALVE

**WARNING: DO NOT REMOVE RESERVOIR NITROGEN FILLER CAP OR ATTEMPT TO CHANGE NITROGEN PRESSURE. DAMAGE TO SHOCK ABSORBER CAN OCCUR.**

Shock absorbers equipped with rebound adjust and compression adjust low speed and high speed are preset. It is recommended that you check the settings by counting the number of full clicks in clockwise until adjuster stops. Back the adjuster out the same number of full clicks you turned the adjuster in. Note these settings in the TUNING NOTES Section.

## FLOAT 3 EVOL R INSTALLATION

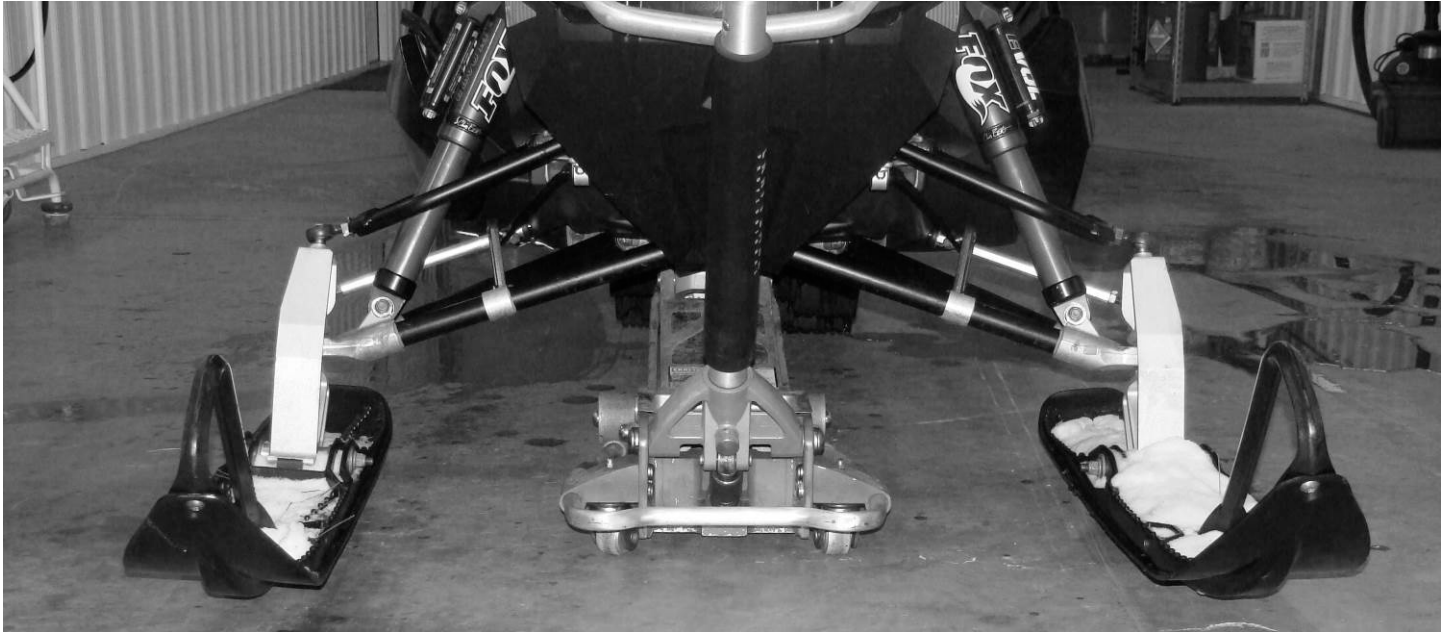

### FLOAT 3 EVOL R

- Step 1 Ensure that your snowmobile is safely supported with a floor jack or jack stand and the skis are off the ground. The suspension should be fully extended before removing the stock shocks. Install your FLOAT 3 EVOL R shock absorbers with the air sleeve oriented as pictured above.
- Step 2 Torque the original hardware to the manufacturer's specifications. FOX FLOAT 3 shocks air chambers do come pre-pressurized, but it is recommended that you check the air pressure on the initial setup before riding.

## FLOAT 3 EVOL R SETUP



Step 1 Ensure that your snowmobile is safely supported with a floor jack or jack stand and the skis are off the ground. Remove the EVOL air spring filler cap.

NOTE: ALWAYS SET EVOL CHAMBER AIR PRESSURE BEFORE SETTING MAIN CHAMBER AIR PRESSURE.

Step 2 Thread the pump onto the EVOL air filler valve until it is fully seated and air pressure registers on the pumps high pressure scale.

NOTE: WHEN YOU ATTACH THE PUMP, THE HOSE AND GAUGE WILL FILL WITH AIR FROM THE AIR CHAMBER RESULTING IN A LOWER AIR PRESSURE THAN THE SHOCK WAS ORIGINALLY SET AT, THIS IS NORMAL.

Step 3 Pump the shock up to the desired air pressure setting. You can decrease air pressure by pushing the BLACK-BLEED valve on pump. (WARNING: DO NOT EXCEED 300PSI IN THE EVOL - CHAMBER)

Pushing the bleed valve halfway down and holding it there will allow air to escape continuously from the pump and shock. Pushing the bleed valve all the way down and releasing it will allow only a small amount of pressure to escape (micro-adjust). When unthreading the pump from the Schrader valve, the sound of air loss is from the pump hose only and not the shock. Your shock pressure will not change.



Step 4 Thread the pump onto the MAIN air filler valve until it is fully seated and air pressure registers on the pumps low pressure scale.

Step 5 Pump the shock up to the desired air pressure setting. You can decrease air pressure by pushing the BLACK-BLEED valve on pump. (WARNING: DO NOT EXCEED 150PSI IN THE MAIN CHAMBER)

Step 6 Lower the vehicle to the floor and remove the jack. Push down on the front bumper 3 times to settle the front end. Measure ground clearance of the vehicle, with the rider on board, from previous measuring point of the chassis. This will be measurement C (Example 7.0 inches) Ride Height

Step 7 **B - C = new Sag Example 11.125" - 7.0"= 4.125"of sag**

Step 8 In our example, you would have to increase the MAIN air chamber pressure to increase ride height and reduce sag, by repeating previous steps one through four. However, if the ride height would have been too high and the sag too low, you would have to decrease the MAIN air chamber pressure.

Full Extension – Ride Height = Sag

Step 9 Reinstall the air spring filler valve caps.

## TUNING THE FLOAT 3 EVOL R

### SPRING FORCE

At this point you have set the sag for your vehicle by adjusting the MAIN air chamber pressure. Your spring force should be near its optimal setting. If you feel that the front of the vehicle is too low as you are riding, increase the MAIN air chamber pressure by 5psi. If the vehicle is too high, decrease the main air chamber pressure by 5psi.

If you feel that you are passing through your available travel too quickly on big bumps or have too much roll in corners, try increasing the EVOL air chamber pressure by 10 PSI. If you feel that you are not fully utilizing your available travel or the sled does not roll over easy in corners (deep snow powder turns), try decreasing the EVOL air chamber pressure by 10 PSI.

- Step 1 Lift the vehicle's front end off the ground.
- Step 2 Release the air pressure from the MAIN air chamber.
- Step 3 Re-set the EVOL air chamber pressure. (Do not exceed 300 psi)
- Step 4 Re-set the MAIN air chamber pressure. (Do not exceed 150 psi)
- Step 5 Reinstall air spring filler caps.

## REBOUND ADJUST

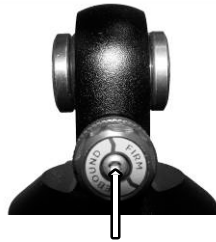

Rebound Adjuster

The Rebound Adjust feature on your FLOAT 3 EVOL R shocks gives you the ability to externally adjust the shock rebound damping. Adjustments are made by turning the RED knob or using a small flat-bladed screwdriver to turn the adjuster on the Air Sleeve Body Cap located on the end of the shock absorber.

For slower rebound, turn the knob/screw clockwise. The rebound adjuster has about 20 clicks of adjustment. The factory setting is 12 clicks out. The performance of the shock at this setting is close to the performance of the non-adjustable shock and is a good all-around setting.

The rebound damping affects how quickly the shock extends (rebounds). This adjustment affects how quickly the skis rebound when travelling through a series of large bumps and how quickly the front end responds in the corner.

The optimum rebound setting is usually found with the minimum damping required to give acceptable control. Excessive rebound damping will typically be felt as suspension "packing." This can often be seen or felt as the vehicle travels through a series of similar-sized, successive bumps. It works well for the first two or three bumps and then bottoms hard on the third or fourth bump. This is because the shock has not rebounded quickly enough, and the shock "packs" into compression.



## MAINTENANCE

PROPER INSPECTION AND MAINTENANCE IS ESSENTIAL TO MAINTAIN THE PERFORMANCE AND RELIABILITY OF YOUR SHOCK ABSORBERS.

You should keep the shock clean and free of dirt, ice and snow.

It is important to keep the shock absorbers clean and free of residue. The Samurai Sealing System in the air sleeve will clean deposits from the shock body and reduce the amount of debris entering the air sleeve. This will add to main air sleeve seal life. When cleaning the vehicle avoid using a high pressure washer near the seals as this could drive debris inside the shock air sleeve.

Ideally, the shocks should be clean around the adjusters when changing the damping setting (if fitted). A small blast of contact cleaner or brake cleaner before making adjustments will keep these parts clean and operating smoothly for years.

The service interval depends on how frequently and severely the snowmobile is ridden. As a guideline, if you race every weekend, you may want to change the oil in your shock at least once during the season. Otherwise, it is generally recommended to service the air sleeves at a minimum of once per year, with complete shock service every 3000 to 5000 miles. FOX or an authorized factory service center can perform these procedures.

## SERVICE

Contact the FOX Service Center at 1.831.740.4619 or [psservicemw@ridefox.com](mailto:psservicemw@ridefox.com) to receive a return authorization number before shipping the shocks to one of the following service centers:

FOX Powersports Service  
130 Hangar Way  
Watsonville, CA 95076

FOX Midwest Service  
Center 13461 Dogwood  
Drive Baxter, MN 56425

## WARRANTY

All FOX products have a one-year warranty on defects in materials or workmanship. Please view the full warranty terms and conditions at [www.ridefox.com](http://www.ridefox.com) Help Center/Powersports/ Warranty or Contact a representative at:

1.800.FOX.SHOX (1.800.369.7469). A service RMA will be issued.